

Power Conversion in Line-Powered Equipment

National Semiconductor
 Application Note 1061
 Jon Cronk
 October 1996



Power Conversion in Line-Powered Equipment

Most equipment used in the office or home draws its power from the AC line. This line may be between 90 V_{AC}–264 V_{AC} and 47 Hz–63 Hz, depending on which portion of the world the equipment is located. However, the internal circuitry and motors rarely operate at these voltages. It now becomes necessary to provide Power Conversion within the equipment. This conversion means a power supply.

The following examples will describe typical power needs within line powered equipment and methods to solve those power needs. *Figure 1* shows an example of a power supply requirement for any given piece of line powered equipment.

The AC input line must be converted by the power supply to provide three DC output voltages which are well regulated over input line and output load. Most circuitry requires low output ripple on its supply voltage. Output ripple is generally specified to be no more than 1% of the output voltage.

The power conversion technique we will address includes a line transformer which provides safety isolation from the line

voltage. The line transformer is the only portion of the power supply which needs to meet UL1950, CSA950, or EN60950 (IEC950) standards. All voltages produced by the transformer will be assumed to meet the requirements for SELV (Safe Extra Low Voltage) circuits. These transformers may be purchased as catalog items, or may be specified with custom requirements.

The power supply following the isolation transformer (see *Figure 2*) can be easily designed using National Semiconductor's Power ICs. Standard data sheets include design procedures and application hints on the use of all parts. Other parts will be supported with design software providing a complete solution.

CONVERTING LINE VOLTAGE TO SAFE LOW VOLTAGE

A line frequency transformer will be used to convert the hazardous line voltage to an isolated safe low voltage. One must understand the characteristics of low frequency line transformers to begin to design this type of power supply.

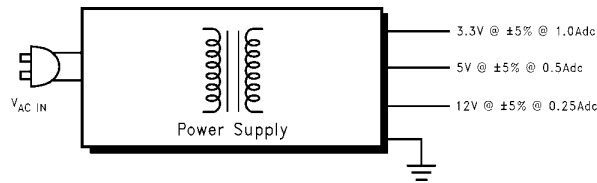

FIGURE 1. Typical Power Supply Requirement

TL/H/12896-1

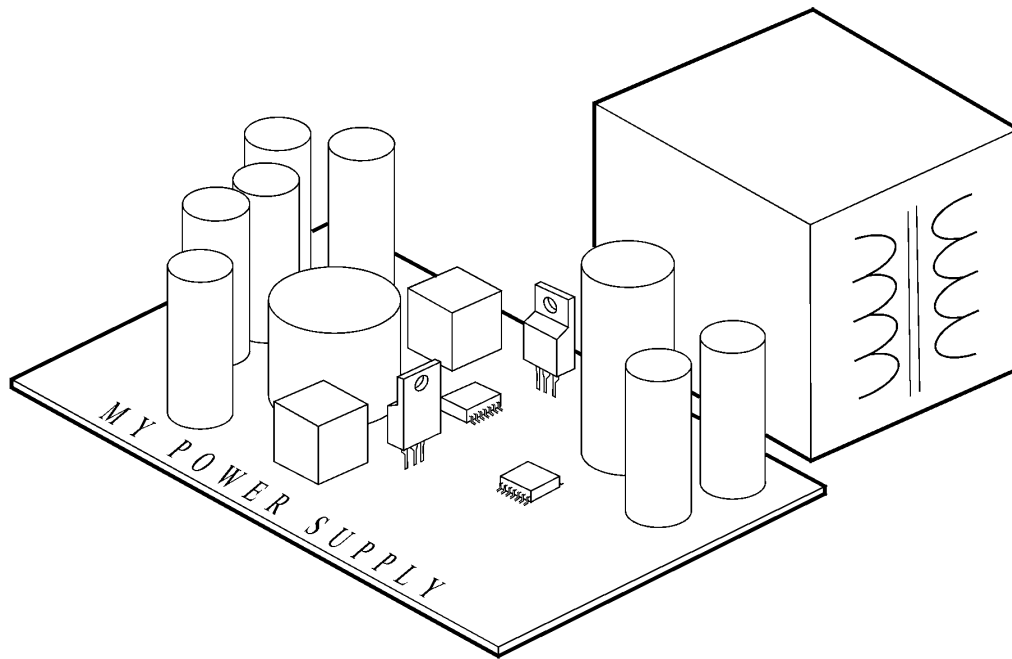

FIGURE 2. Power Supply Solution Using Isolation Transformer and Low-Voltage DC/DC Converters

TL/H/12896-2

AN-1061

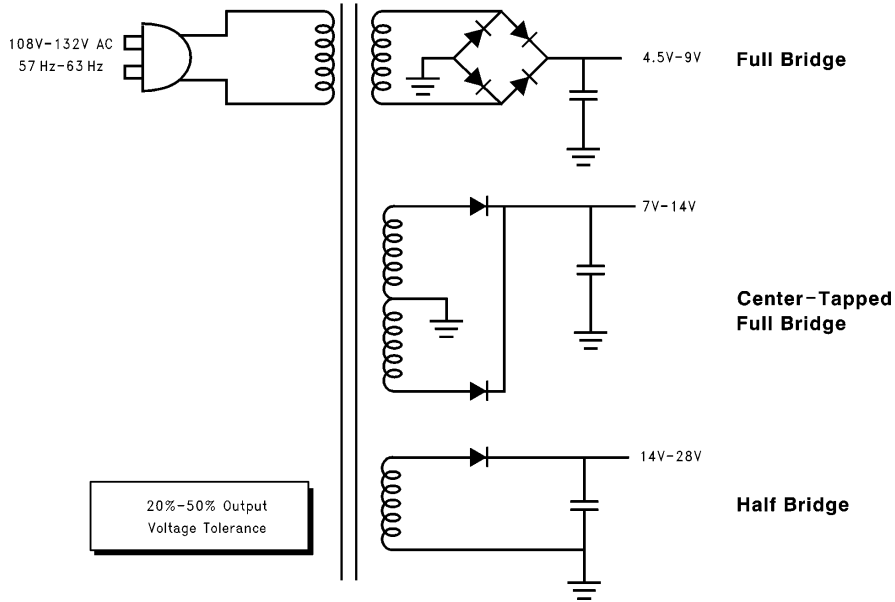

FIGURE 3. AC Line Rectification Methods

TL/H/12896-3

Figure 3 shows three different rectification techniques to develop a basic DC voltage source. The first, Full Bridge, is most efficient in the transformer, but requires a four diode rectification bridge. The second, Center-Tapped Full Bridge, requires more turns of wire in the secondary, but saves two diodes. The output ripple on both Full Bridge designs is the same. The last, Half Bridge, is a low cost method best for low output power. The half bridge creates a DC bias on the winding and as a result should only be used for very low current outputs. A half bridge will also give higher output ripple.

Output regulation is poor in a line transformer. If one assumes an ideal transformer, the regulation of the output will be no better than the input. Typical design requirements for input voltage is nominal $\pm 10\%$ (some require $\pm 12.5\%$). In the case above, nominal is 120 V_{AC}.

Given a line variation of 10%, the output voltage tolerance is no better than $\pm 10\%$. Adding the resistance of the transformer windings results in output voltage variation with load.

The change in output voltage with load is a complex function. The definitive analysis can be found in a paper published by O.H. Shade in the July, 1943 Proceedings of the Institute of Radio Engineers entitled *Analysis of Rectifier Operation*. Although Shade used vacuum tube rectifiers, the analysis still holds true for modern diodes. In general, load regulation can vary from 10% to 40%. In the example above, the load regulation is 25%.

The size of the transformer is a function of a number of items: output power, load regulation, efficiency, maximum allowable temperature rise, and cost (core material is the primary variable).

Since the output voltages are poorly regulated, they can not be used as the output of the power supply. Additional regulation is necessary.

SELECTING THE DC/DC CONVERSION METHOD

As shown in Figure 4, there are generally three ways to provide the tightly regulated DC outputs required in this example.

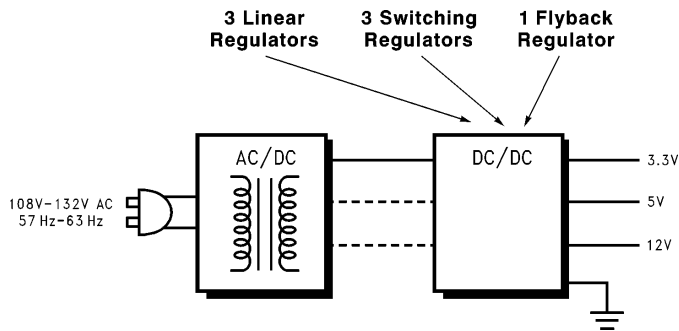

FIGURE 4. DC/DC Converter Options

TL/H/12896-4

The first is using three linear regulators from three different transformer outputs. This is the lowest efficiency solution. However, it is also the easiest to design and has the lowest component count. This solution requires an output winding for each supply to obtain acceptable power loss in the linear regulators.

The second is using three switching regulators (buck DC/DC) from a single transformer output. This provides excellent efficiency. However, the design complexity increases slightly and component count may increase. This solution requires only a single poorly regulated output from the transformer.

The third is a single flyback switching regulator. This also provides good efficiency, but is even more complex. The example above has no compelling reason to use a flyback regulator. A more appropriate set of requirements for this type of switching regulator will be presented later.

The solution in *Figure 5* shows how one would use linear regulators to obtain the desired regulated output voltages. The bulk capacitors across the rectified transformer windings may be reduced depending on the transformer being used. The linear regulators provide exceptional rejection of the 120 Hz ripple voltage found at the output of the transformer as long as the voltage does not go below the dropout voltage of the linear regulator. The regulator output capacitors are selected using the Application Hints in the data-sheet for each part.

Each linear regulator must have a heat sink to prevent over heating. All calculations for power loss in the linear regula-

tors will be performed at 132 V_{AC} input to the transformer and full load on the outputs. This is the worst case condition. The power loss in the linear regulator can be described as:

$$P_{LOSS} = V_{IN} \times I_{GND} + (V_{IN} - V_{OUT}) \times I_L$$

Where V_{IN} is the average DC from the transformer, I_{GND} is the ground pin current at full load (see data sheet), and I_L is the output current.

The LM3940 is the low dropout regulator chosen for the 3.3V output at 1 A_{DC}. V_{IN} is approximately 5.5 V_{DC}, and the calculated power loss is 2.8W (I_{GND} = 110 mA).

The LP2960 is the low dropout regulator chosen for the 5.0V output at 0.5 A_{DC}. V_{IN} is approximately 7.3 V_{DC}, and the calculated power loss is 1.3W (I_{GND} = 21 mA, max).

The LM2952 is the low dropout regulator chosen for the 12V output at 0.25 A_{DC}. V_{IN} is approximately 15.9 V_{DC}, and the calculated power loss is 1.3W (I_{GND} = 21 mA, max).

The total output power is 8.8W and the total power loss is 5.4W. As a result, the line transformer must provide 14.2W. If lower cost non-LDO were used, there would be an additional 3.8W loss (because of the higher input voltage required, countered by lower supply current). This would result in a 27% increase in transformer size.

If a simple transformer with a single winding was used with LDO regulators, the extra loss would be 14.9W. 12W of this would be the loss in the 3.3V regulator dropping the voltage down from a 14V winding! As a result, 3 windings are required.

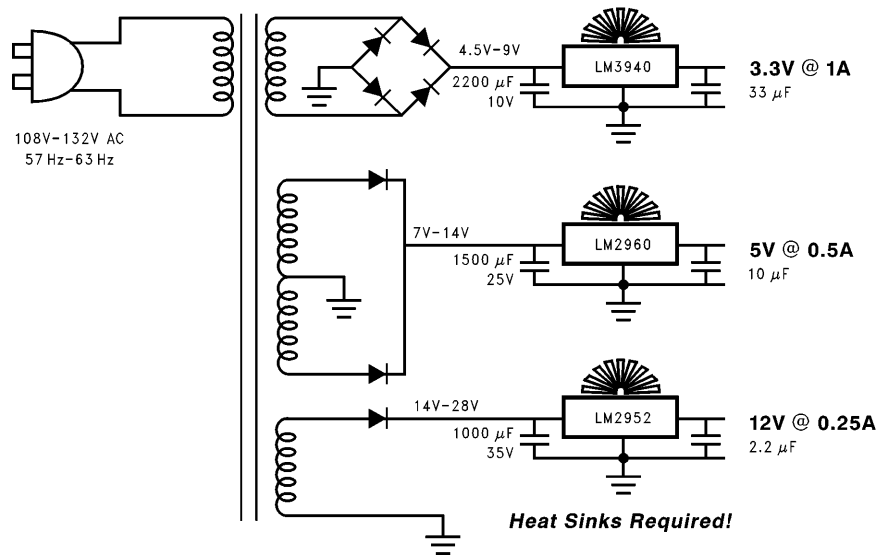
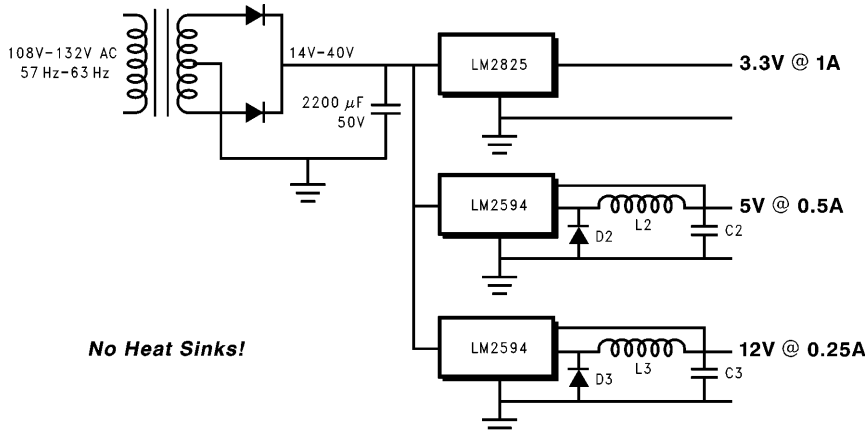

FIGURE 5. Power Supply Solution Using Linear Regulators

TL/H/12896-5



TL/H/12896-6

FIGURE 6. Power Supply Solution Using Step-Down Switching Regulators

Figure 6 shows a solution using three switching regulators. The average voltage supplied by the line transformer is 14V–40V. This voltage represents a relaxation of the line transformer load regulation (from 25% to 40%) and can allow a smaller transformer. Again, the size of the input capacitor may be reduced and 120 Hz ripple rejection is excellent.

None of the switching regulators requires a heat sink given proper heat sinking to the PCB (Printed Circuit Board).

The components are selected by a software design tool, Switchers Made Simple (ver. 4.2.1), which is available for use with SIMPLE SWITCHER DC/DC Converters. National's WEB site at <http://www.national.com/> is the best place to get a current version.

The overall efficiency of this switching regulator solution is approximately 80%. Therefore, the line transformer only

needs to provide 11W. By reducing the required power, line transformer used in this solution can be 22% smaller than that used in the previous linear regulator solution. Also, only one output winding is required, thus simplifying the transformer manufacture.

DESIGN FOR 3-OUTPUT MODEM POWER SUPPLY

The design of Figure 7, for a modem application, required a DC/DC converter that was easy to configure and had low power loss. The modem was external and required that all output voltages be generated from a single output on a plug in wall transformer. To meet these needs, a multi-output flyback switching regulator was used to regulate the voltage developed by the line transformer. Not only does the use of a switching regulator keep the power loss much lower than if a linear regulator were used, the flyback topology is well suited for providing negative voltages while using one of the positive outputs as the feedback point.

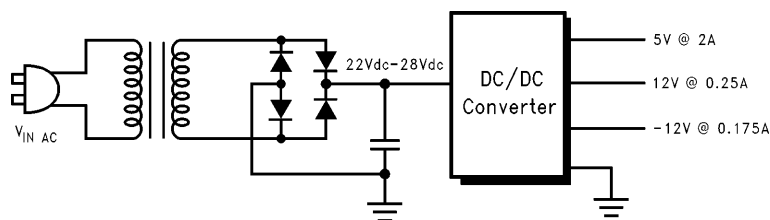

TL/H/12896-7

FIGURE 7. 3-Output Flyback Converter Provides Power for Modem

The easiest way to develop such a DC/DC converter is to generate a SIMPLE SWITCHER converter design with the software tool "Switchers Made Simple". The customer requirements were entered into the software and the resulting design is shown in *Figure 8*. This DC/DC converter is approximately 75% efficient.

One important thing to note is that only the +5V output is directly regulated. The 12V and -12V outputs will vary over line and load much more than the 5V winding. For example,

if the 5V winding only varies 1% over line and load, the 12V outputs may vary by 5%. This phenomenon is called "cross-regulation". It is a function of the design of the flyback transformer and the line and load range on all the outputs. For more information on this subject, reference a paper published in the 1995 PCIM Proceedings entitled *Improving Cross Regulation of Multiple Output Flyback Converters* written by J. Marrero of National Semiconductor.

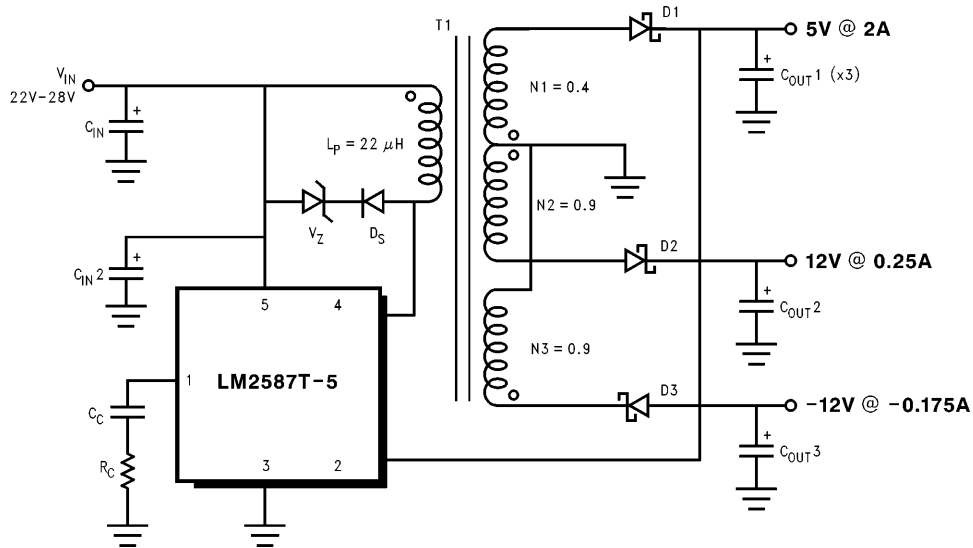

FIGURE 8. Schematic for Power Supply of *Figure 7*

TL/H/12896-8

U ₁	5.00A	National	LM2587T-5
T ₁	(Software provides detailed specification . . .)		
C _{IN}	270.00 μF*	Nichicon	UPL1J271MRH
C _{IN2}	100.00 nF	AVX	SR595C104KAA
C _{OUT1}	2.70 mF (×3)	Nichicon	UPL1V272MRH
C _{OUT2}	330.00 μF	Nichicon	UPL1V331MPH
C _{OUT3}	270.00 μF	Nichicon	UPL1V271MPH
R _C	3.00 kW	Dale	CCF-07302J
C _C	330.00 nF	AVX	TAPA334K035R
D ₁	Schottky	Motorola	MBR745
D ₂	Schottky	Motorola	MBR1100
D ₃	Schottky	Motorola	MBR1100
V _Z	20.00V	Motorola	SA20A
D _S	Ultrafast	Motorola	MUR120

*May require a larger value if used as the bulk capacitor for the line transformer.

FIGURE 9. Component Summary for the Circuit of *Figure 8*, as Generated by Switchers Made Simple 4.2

UNDERVOLTAGE LOCKOUT

Although the power supply is designed to operate properly over a given input voltage range, there is no guarantee that the line voltage available to the customer will always stay within that range. For over-voltage and transient conditions, we can protect our power supply and other internal circuitry by using a zener diode to clamp the input voltage. For brown out conditions we can use an undervoltage lockout circuit in conjunction with the shutdown pins on the Simple Switchers.

The undervoltage lockout must have special features due to the load regulation of the 60 Hz transformer. If we were to set a fixed on/off voltage for the power supply the following sequence of events would occur:

1. The input voltage falls below our minimum operating point (say 105 V_{AC}).
2. The undervoltage circuit trips and turns off the power supply and equipment.
3. The 60 Hz transformer is unloaded and the output voltage jumps up above the on/off trip point.
4. The power supplies try to start and pulls the output of the 60 Hz transformer down again.
5. Steps 2 through 4 repeat constantly causing the power supplies and equipment to oscillate on and off.

The problem is the difference between no-load and loaded output voltage of the 60 Hz transformer. Our undervoltage

lockout must be able to turn on the power supplies once the input voltage is within our operating range (about 108 V_{AC}). But, once the supplies turn on, recognize that the output voltage will be pulled down, and not turn off until the input falls below our operating minimum (about 100 V_{AC}).

By using an undervoltage circuit with hysteresis (illustrated in *Figure 10*), we can prevent the power supply from oscillating on and off.

V_(turn on) is the no load voltage from the transformer. This is very close to

$$108 \cdot \frac{N_s}{N_p} \cdot \sqrt{2}$$

V_(turn off) is the full load voltage from the transformer at 100 V_{AC}. This value is very sensitive to the load conditions for each design, and should be measured on the bench during design.

ΔV is the difference between these two voltages, and is the value we will use for the undervoltage lockout hysteresis.

The schematic and equations of *Figure 11* will provide a hysteretic undervoltage lockout circuit design. Some assumptions have been made to simplify the equations, primarily that R_h ≫ R₁ and R₂. Also, the current through R₁ and R₂ should be at least 10 times greater than the input current to the comparator. The LM6511 input current is typically less than 50 nA (datasheet maximum over all conditions is 200 nA which occurs at -40°C).

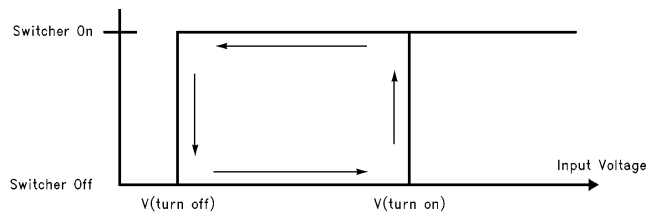

- V_(turn on) = No load voltage from transformer @108 V_{AC}.
- V_(turn off) = Full load voltage from transformer @100 V_{AC}
- ΔV = V_(turn on) - V_(turn off); Hysteresis

ΔV

TL/H/12896-9

FIGURE 10. Hysteresis Controls Turn-on and Turn-off Thresholds of Undervoltage Circuit

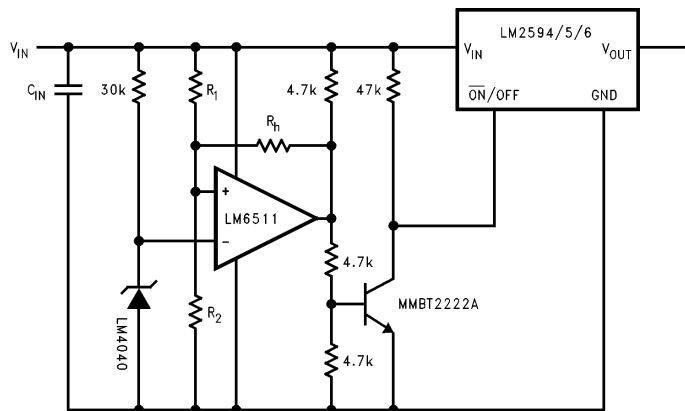

FIGURE 11. Undervoltage Lockout Circuit with Hysteresis

TL/H/12896-10

Once the circuit has been incorporated with the complete power supply and powered circuitry, the values of R_h , R_1 , and R_2 can be optimized.

Make sure to check that the regulator you are using turns on by grounding the on/off pin. Some regulators turn off when grounding this pin. If the logic needs to be inverted, just swap the inputs to the comparator.

COMPARISON OF POWER SUPPLY SOLUTIONS

Linear Regulators	Switching Regulators
No EMI from power supply	Smaller line transformer <ul style="list-style-type: none"> • Lower power • One winding • Poorer regulation okay
Fewer components in converter	One diode bridge and bulk capacitor required
Typically lower cost	No heat sinks*

*Small heat sinks may be required at higher ambient temperature or output power levels

FIGURE 12. Linear Regulator Solutions vs Switching Regulator Solutions

As indicated in *Figure 12*, each type of regulator has its own strengths and weaknesses.

The linear regulator provides a fast simple solution. Overall, the linear regulator will be the lowest cost solution. The drawbacks are a complicated line transformer with multiple output windings, low efficiency, and heat sinks to dissipate the power lost in the regulator.

- A multi-output line transformer, with output voltages close to the desired levels, can be used with low-dropout linear regulators on each output. This yields a low-component-count power supply.

These LDOs may include:

- LP2980/2 for ≤ 50 mA loads
- LP2950/51/81 for ≤ 100 mA loads
- LP2952/53/54/57 for ≤ 250 mA loads
- LP2960 for ≤ 500 mA loads
- LM3940 for ≤ 1 Amp loads

Switching regulators provide a more efficient solution at the expense of slightly greater complexity. The line transformer can be less expensive than that used for the linear regulator. One benefit of higher efficiency is the ability to omit heat sinks unless the ambient temperature is very high ($> 50^\circ\text{C}$ at

rated current). In some cases the cost of adding a heat sink to a linear regulator is more than a switching regulator.

A single-output line transformer can be used with multiple buck regulators. This yields a high-efficiency power supply with independent control of each output. Or, you could use a single multi-output flyback switching regulator. This yields a relatively simple, high-efficiency supply.

One issue which may arise is EMI from the switching regulators getting back into the AC line. Linear regulators do not generate any EMI. Switching regulators may require a filter stage at the output of the line transformer if the bulk capacitor does not provide sufficient attenuation at the switching frequency.

While new requirements for harmonic content and power factor correction (PFC) are being put in place in Europe, they will not be required on the sub-50W power supplies we are discussing here. Power supplies above 75W input power will require input stages to limit harmonic distortion. All line frequency transformers feeding into an output rectifier and bulk capacitor have distorted input currents. For this reason, none of the solutions here are intended to address these requirements.

SIMPLE SWITCHER CONVERTERS

While there are many types of DC/DC voltage converters on the market, there are few that combine the ease-of-use and adaptability of the SIMPLE SWITCHER DC/DC converters. See *Figure 13* for a selection guide of these converters.

SIMPLE SWITCHER products offer guaranteed system specifications, such as maximum output voltage tolerance, not just the tolerance of a subsection of the integrated circuit.

In addition, a SIMPLE SWITCHER is easy to configure, with a variety of standard output voltages available. A few external components are required, and they are fully specified in the product documentation. Components which may be unfamiliar to the system designer, such as magnetics, are available as standard part numbers from other vendors.

“Switchers Made Simple” design software is also available, to customize a SIMPLE SWITCHER converter for a specific application.

See our WEB site at <http://www.national.com/models/switch/switch.htm> (Sept. 6, 1996).

Buck Converters	Switching Frequency	Output Current	Input Voltage Range	Features
LM2825	150 kHz	1.0A	4.75 V _{DC} -40 V _{DC}	Fully integrated DC/DC Converter IC in a 24-pin DIP requiring no external components with TTL on/off and soft-start
LM267X future part, check for availability	260 kHz	0.5A 1.0A 3.0A	7 V _{DC} -40 V _{DC}	High efficiency DMOS, sync to 400 kHz, TTL on/off, soft-start, μ P reset and error flag, SO-8 at 1.0A.
LM2594	150 kHz	0.5A	5 V _{DC} -40 V _{DC}	SO-8, TTL on/off
LM2595	150 kHz	1.0A	5 V _{DC} -40 V _{DC}	TTL on/off
LM2596	150 kHz	3.0A	5 V _{DC} -40 V _{DC}	TTL on/off
LM2597	150 kHz	0.5A	5 V _{DC} -40 V _{DC}	SO-8, Soft-start, μ P reset and error flag, TTL on/off
LM2598	150 kHz	1.0A	5 V _{DC} -40 V _{DC}	Soft-start, μ P reset and error flag, TTL on/off
LM2599	150 kHz	3.0A	5 V _{DC} -40 V _{DC}	Soft-start, μ P reset/error flag, TTL on/off
LM2574 LM2574HV	52 kHz	0.5A	7 V _{DC} -40 V _{DC} 7 V _{DC} -60 V _{DC}	TTL on/off
LM2575 LM2575HV	52 kHz	1.0A	7 V _{DC} -40 V _{DC} 7 V _{DC} -60 V _{DC}	TTL on/off
LM2576 LM2576HV	52 kHz	3.0A	7 V _{DC} -40 V _{DC} 7 V _{DC} -60 V _{DC}	TTL on/off
Flyback or Boost Converters		Switch Current		
LM2585	100 kHz	3.0A	4 V _{DC} -40 V _{DC}	
LM2586	100 kHz	3.0A	4 V _{DC} -40 V _{DC}	Synch, on/off, freq. adj to 200 kHz
LM2587	100 kHz	5.0A	4 V _{DC} -40 V _{DC}	
LM2588	100 kHz	5.0A	4 V _{DC} -40 V _{DC}	Synch, on/off, freq. adj to 200 kHz
LM2577	52 kHz	3.0A	4 V _{DC} -40 V _{DC}	

FIGURE 13. SIMPLE SWITCHER® Power Converters

LIFE SUPPORT POLICY

NATIONAL'S PRODUCTS ARE NOT AUTHORIZED FOR USE AS CRITICAL COMPONENTS IN LIFE SUPPORT DEVICES OR SYSTEMS WITHOUT THE EXPRESS WRITTEN APPROVAL OF THE PRESIDENT OF NATIONAL SEMICONDUCTOR CORPORATION. As used herein:

1. Life support devices or systems are devices or systems which, (a) are intended for surgical implant into the body, or (b) support or sustain life, and whose failure to perform, when properly used in accordance with instructions for use provided in the labeling, can be reasonably expected to result in a significant injury to the user.
2. A critical component is any component of a life support device or system whose failure to perform can be reasonably expected to cause the failure of the life support device or system, or to affect its safety or effectiveness.



National Semiconductor Corporation
Americas
Tel: 1(800) 272-9959
Fax: 1(800) 737-7018
Email: support@nsc.com

National Semiconductor Europe
Fax: +49 (0) 180-530 85 86
Email: europe.support@nsc.com
Deutsch Tel: +49 (0) 180-530 85 85
English Tel: +49 (0) 180-532 78 32
Français Tel: +49 (0) 180-532 93 58
Italiano Tel: +49 (0) 180-534 16 80

National Semiconductor Southeast Asia
Fax: (852) 2376 3901
Email: sea.support@nsc.com

National Semiconductor Japan Ltd.
Tel: 81-3-5620-7561
Fax: 81-3-5620-6179

<http://www.national.com>

National does not assume any responsibility for use of any circuitry described, no circuit patent licenses are implied and National reserves the right at any time without notice to change said circuitry and specifications.