



INGENIERIA
ELECTRONICA, MICROPROCESADORES, ENERGIA

T. DE LOQUI 58 - 9400 RIO GALLEGOS

AC BOARD - SCHEMATIC



Figura 1: Esquemático AC_BOARD



INGENIERIA
ELECTRONICA, MICROPROCESADORES, ENERGIA

T. DE LOQUI 58 - 9400 RIO GALLEGOS

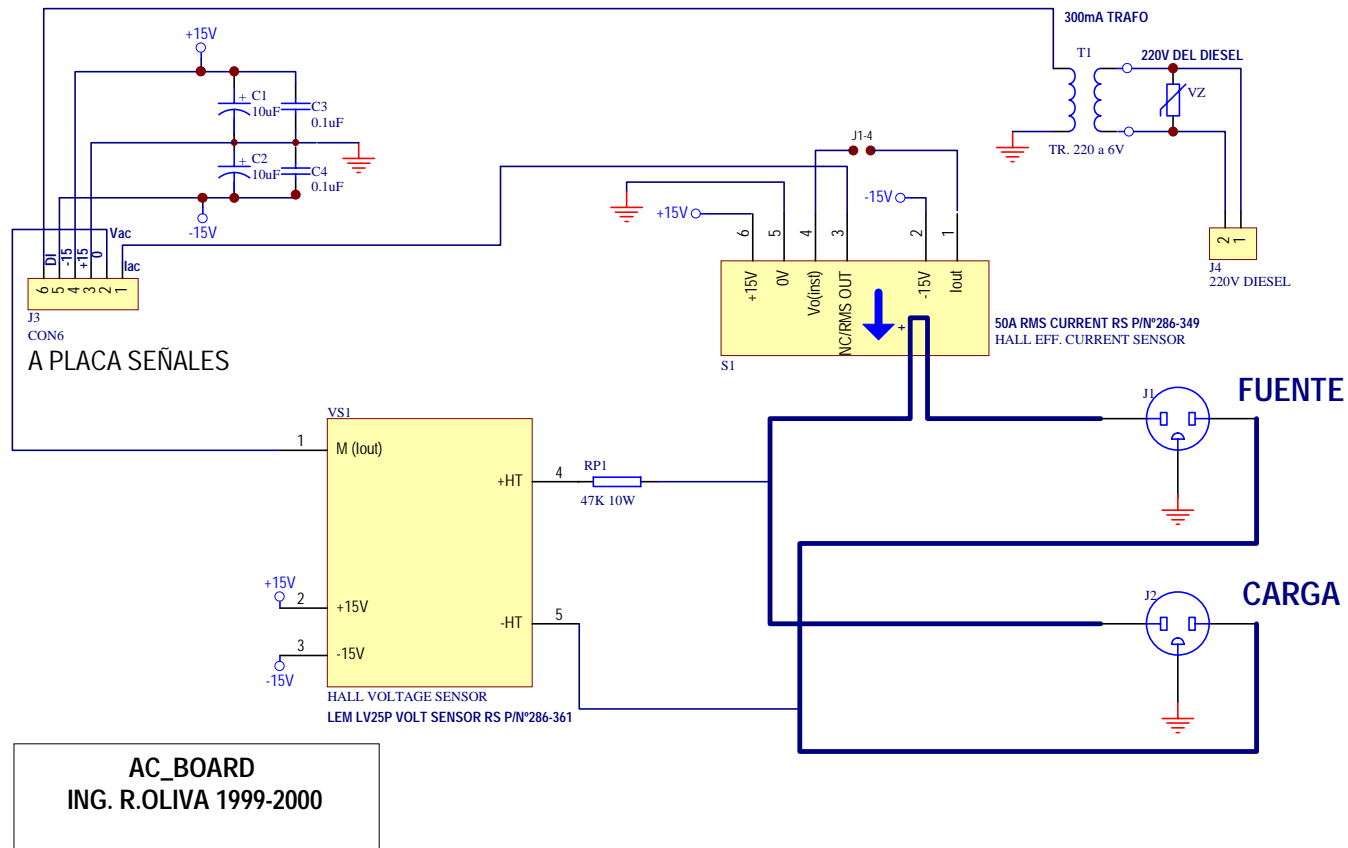
SIGNAL CONDITIONING.

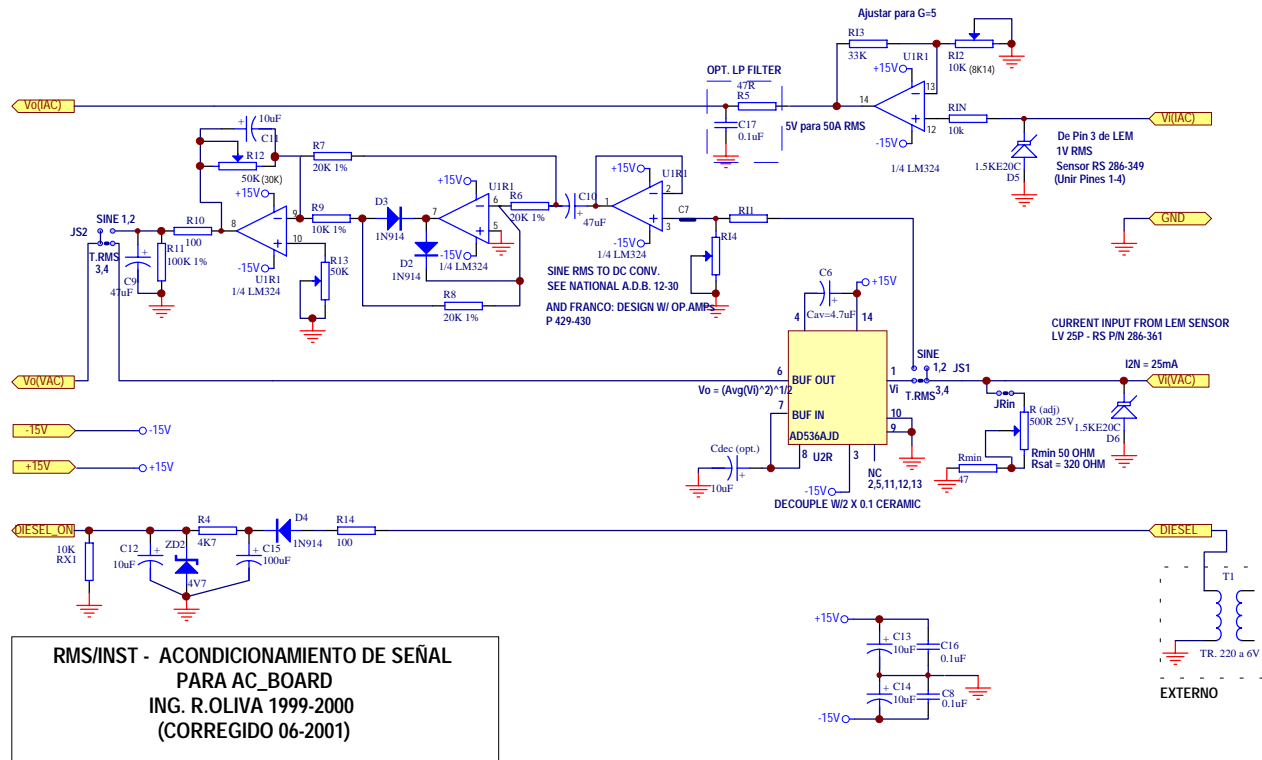

Figure 2 - Typical AC Board Signal Conditioning